

NOTE:

MATERIAL USAGE: 4"

WHEN USING PERFORATOR:
 MAXIMUM NET FREE AREA = 2.65 SQUARE INCHES
 PER 12 INCHES OF PERFORATION
 MAXIMUM OF THREE PERFORATIONS PER PANEL.

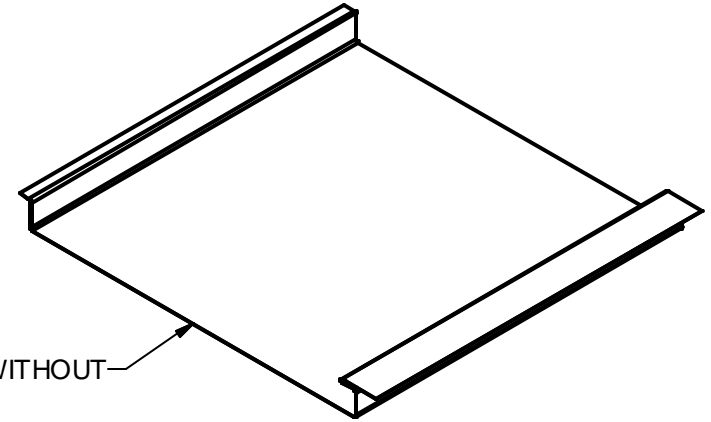

PANEL SHOWN WITHOUT PERFORATIONS

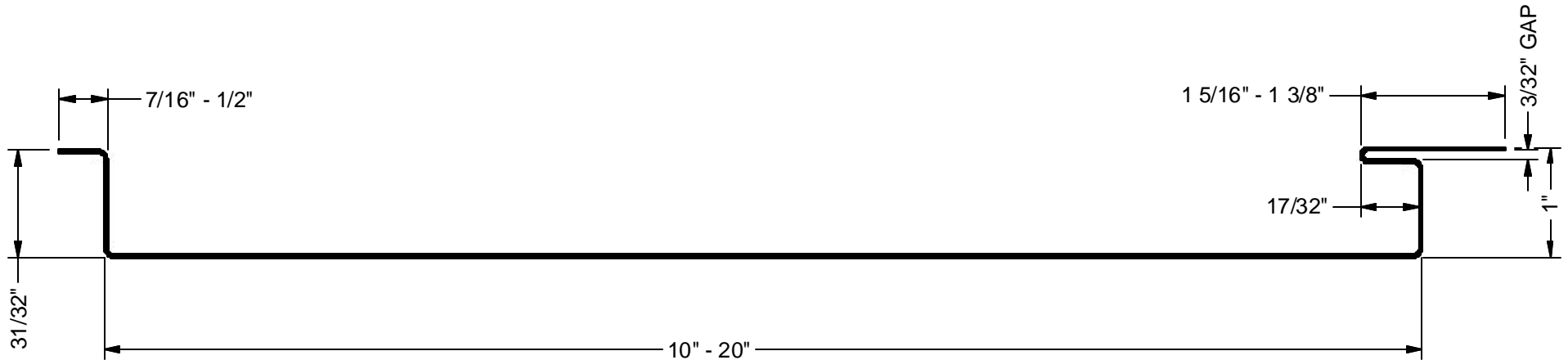

MATERIAL		LENGTH		FINISH		NEW TECH MACHINERY CORP.				
REVISION HISTORY	REV	ECN NO.	DATE	RELEASED BY	TOLERANCES .XX = ± .01 .XXX = ± .005 FRACTION = ± 1/32" ANGLE = ± 1/2°	DRAWN BY	PART NAME			
						SAWYER	1 INCH SOFFET PANEL PROFILE			
						DATE	5/23/2002			
						CHECK BY	SIZE	A	SHEET	1 OF 1
						DATE	SCALE		PART NUMBER	FW1-1
									REVISION 0	